

D STREET

60 FT R.O.W.
30 Ft Wide Paved

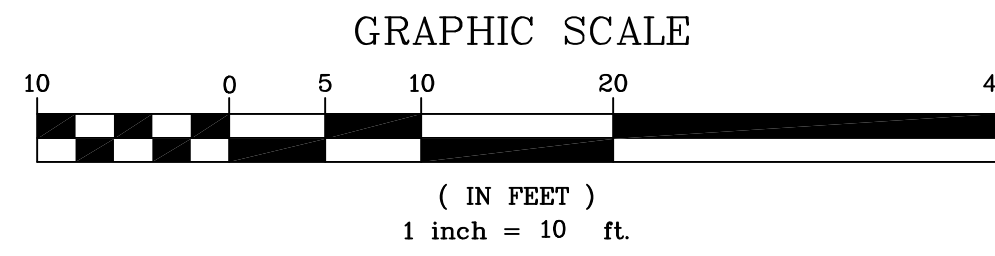

PROPOSED NEW 12 FT DEPRESSED CURB AND REINFORCED CONCRETE APRON (LIMIT OF SIDEWALK AND CURB REPAIR AS DIRECTED BY BORO ENGINEER)
REMOVE EXISTING DEPRESSED CURB AND CONCRETE APRON

PROPOSED NEW 4" THK. CONCRETE SIDEWALK (6" THK. @ DWY.)

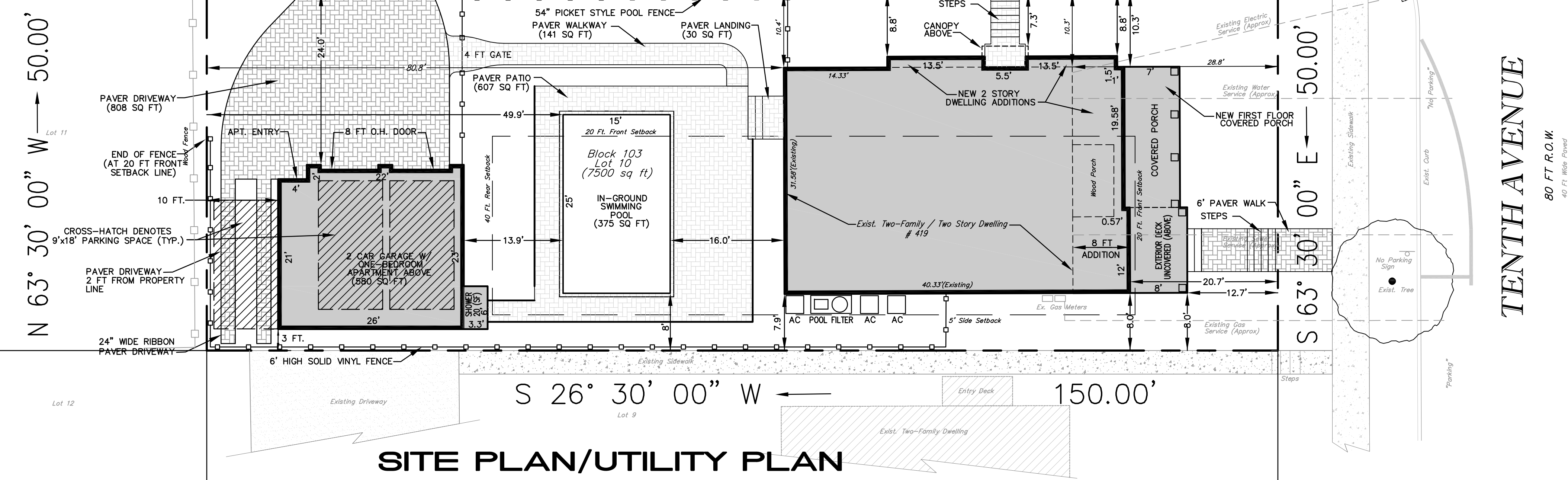

SITE PLAN/UTILITY PLAN

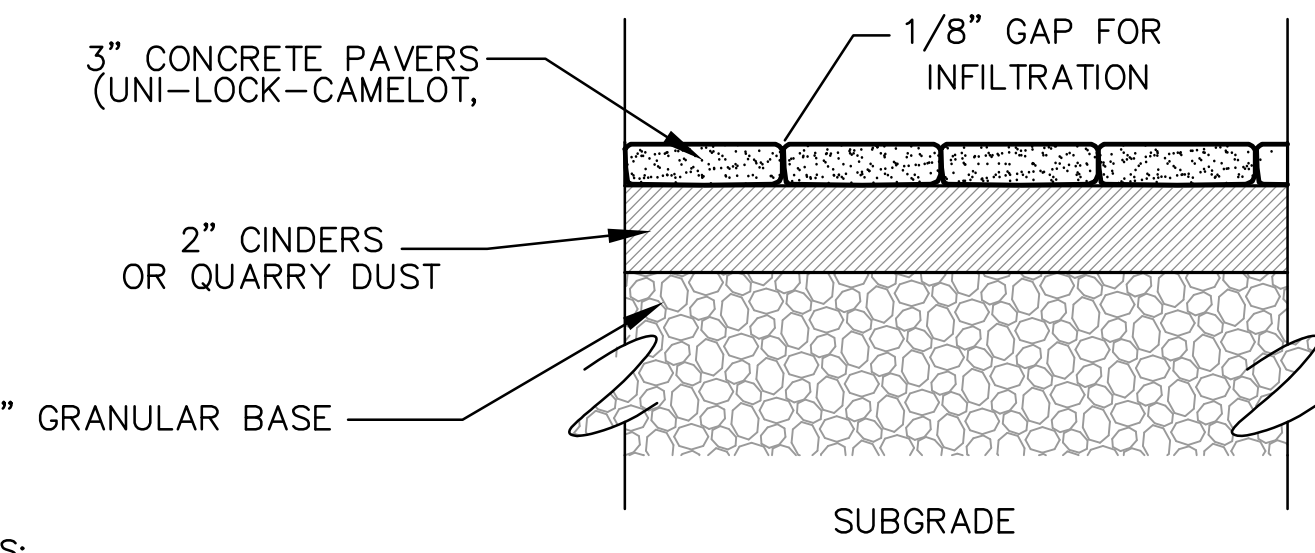

NOTES:
901.08 OR SOIL AGGREGATE DESIGNATED I-5 CONFORMING TO SUBSECTION 901.09 AND SHOWN IN TABLE 901-2 OF N.J. DEPARTMENT OF TRANSPORTATION STANDARD SPECIFICATIONS FOR ROAD AND BRIDGE CONSTRUCTION (1989)
2. SUBGRADE COMPACTION SHALL BE APPROVED BY THE MUNICIPAL ENGINEER.

PAVER DRIVEWAY/WALK DETAIL

N.T.S.

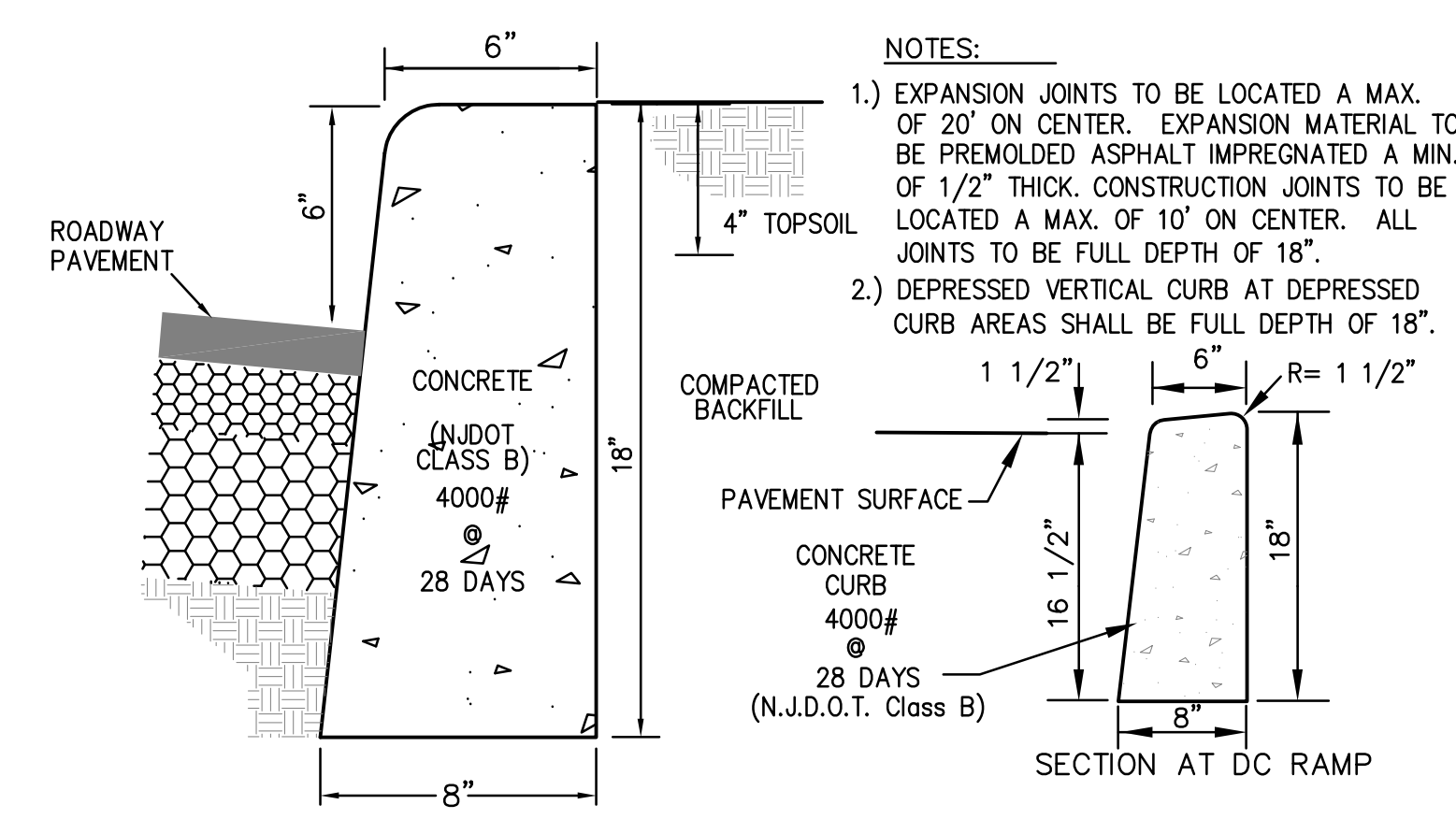

NOTES:
1.) EXPANSION JOINTS TO BE LOCATED A MAX. OF 20' ON CENTER. EXPANSION MATERIAL TO BE PREMOULD ASPHALT IMPREGNATED TO A MIN. OF 1/2" THICK. CONSTRUCTION JOINTS TO BE LOCATED A MAX. OF 10' ON CENTER. ALL JOINTS TO BE FULL DEPTH OF 18".
2.) DEPRESSED VERTICAL CURB AT DEPRESSED CURB AREAS SHALL BE FULL DEPTH OF 18".

VERTICAL CURB

N.T.S.

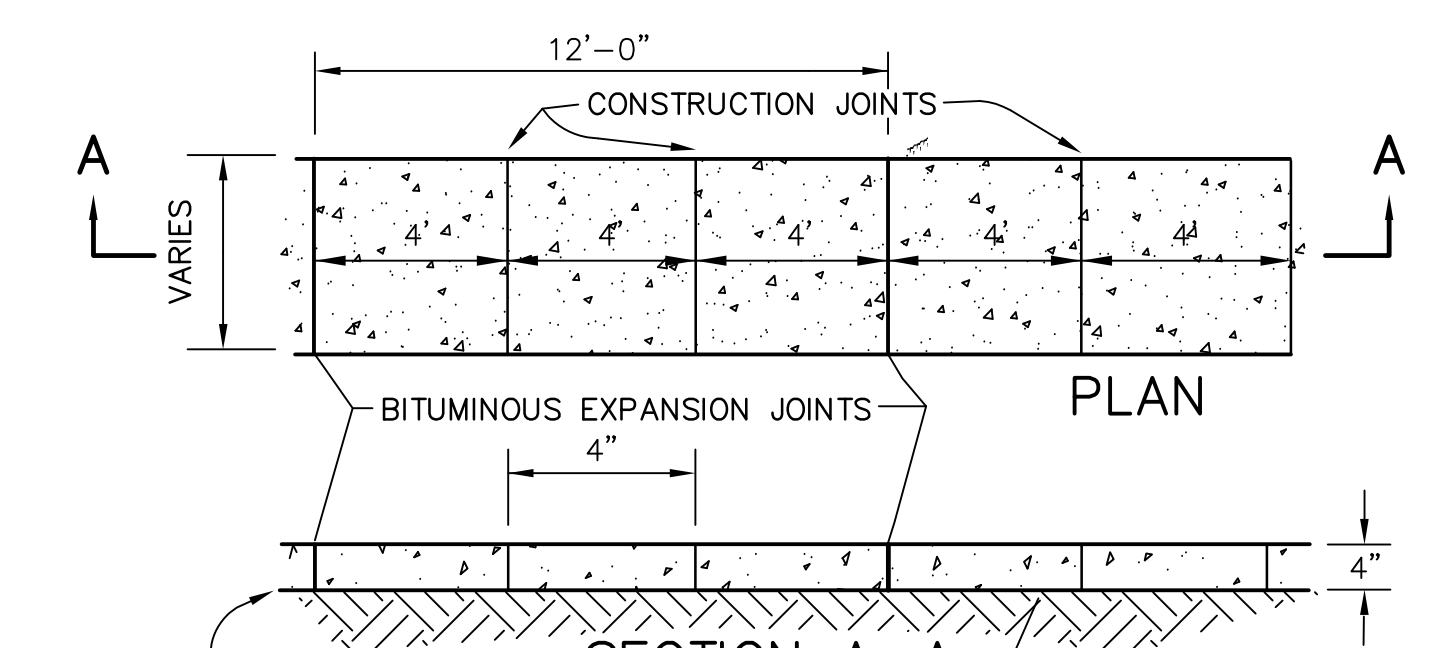

NOTES:
1.) A PREFORMED, BITUMINOUS EXPANSION JOINT 1/2" THICK, 4" WIDE, AND EXTENDING THE FULL WIDTH OF THE WALK, UNBROKEN, SHALL BE INSTALLED EVERY 12 FEET (MINIMUM). CONSTRUCTION JOINTS SHALL BE INSTALLED EVERY 4 FEET THE FULL WALK WIDTH.
2.) THERE SHALL BE A BROOM FINISH WITH THE EDGES FINISHED WITH A SUITABLE TOOL TO PROVIDE A 1/2" RADIUS.

SIDEWALK DETAIL

N.T.S.

D STREET

60 FT R.O.W.
30 Ft Wide Paved

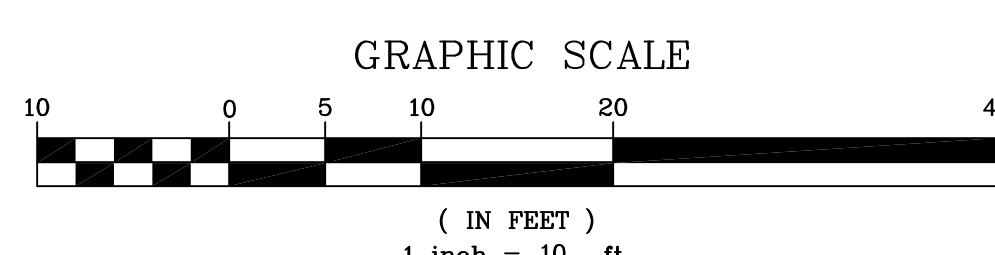

REMOVE EXISTING DEPRESSED CURB AND CONCRETE APRON

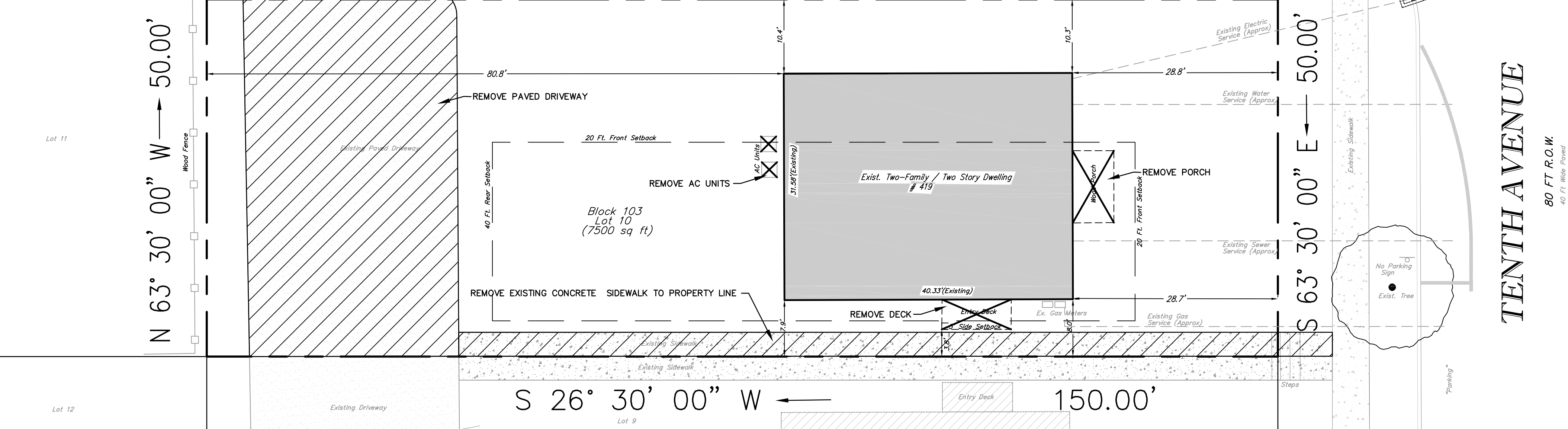

EXISTING CONDITION PLAN/DEMOLITION PLAN

BY: JKR	DATE: 06/27/20	DESCRIPTION: REVISIONS
REV: 1	DATE: 06/27/20	DESCRIPTION: REVISIONS
REV: 2	DATE: 06/27/20	DESCRIPTION: REVISIONS
REV: 3	DATE: 06/27/20	DESCRIPTION: REVISIONS
REV: 4	DATE: 06/27/20	DESCRIPTION: REVISIONS
REV: 5	DATE: 06/27/20	DESCRIPTION: REVISIONS
REV: 6	DATE: 06/27/20	DESCRIPTION: REVISIONS
REV: 7	DATE: 06/27/20	DESCRIPTION: REVISIONS
REV: 8	DATE: 06/27/20	DESCRIPTION: REVISIONS
REV: 9	DATE: 06/27/20	DESCRIPTION: REVISIONS
REV: 10	DATE: 06/27/20	DESCRIPTION: REVISIONS
REV: 11	DATE: 06/27/20	DESCRIPTION: REVISIONS
REV: 12	DATE: 06/27/20	DESCRIPTION: REVISIONS
REV: 13	DATE: 06/27/20	DESCRIPTION: REVISIONS
REV: 14	DATE: 06/27/20	DESCRIPTION: REVISIONS
REV: 15	DATE: 06/27/20	DESCRIPTION: REVISIONS
REV: 16	DATE: 06/27/20	DESCRIPTION: REVISIONS
REV: 17	DATE: 06/27/20	DESCRIPTION: REVISIONS
REV: 18	DATE: 06/27/20	DESCRIPTION: REVISIONS
REV: 19	DATE: 06/27/20	DESCRIPTION: REVISIONS
REV: 20	DATE: 06/27/20	DESCRIPTION: REVISIONS
REV: 21	DATE: 06/27/20	DESCRIPTION: REVISIONS
REV: 22	DATE: 06/27/20	DESCRIPTION: REVISIONS
REV: 23	DATE: 06/27/20	DESCRIPTION: REVISIONS
REV: 24	DATE: 06/27/20	DESCRIPTION: REVISIONS
REV: 25	DATE: 06/27/20	DESCRIPTION: REVISIONS
REV: 26	DATE: 06/27/20	DESCRIPTION: REVISIONS
REV: 27	DATE: 06/27/20	DESCRIPTION: REVISIONS
REV: 28	DATE: 06/27/20	DESCRIPTION: REVISIONS
REV: 29	DATE: 06/27/20	DESCRIPTION: REVISIONS
REV: 30	DATE: 06/27/20	DESCRIPTION: REVISIONS
REV: 31	DATE: 06/27/20	DESCRIPTION: REVISIONS
REV: 32	DATE: 06/27/20	DESCRIPTION: REVISIONS
REV: 33	DATE: 06/27/20	DESCRIPTION: REVISIONS
REV: 34	DATE: 06/27/20	DESCRIPTION: REVISIONS
REV: 35	DATE: 06/27/20	DESCRIPTION: REVISIONS
REV: 36	DATE: 06/27/20	DESCRIPTION: REVISIONS
REV: 37	DATE: 06/27/20	DESCRIPTION: REVISIONS
REV: 38	DATE: 06/27/20	DESCRIPTION: REVISIONS
REV: 39	DATE: 06/27/20	DESCRIPTION: REVISIONS
REV: 40	DATE: 06/27/20	DESCRIPTION: REVISIONS
REV: 41	DATE: 06/27/20	DESCRIPTION: REVISIONS
REV: 42	DATE: 06/27/20	DESCRIPTION: REVISIONS
REV: 43	DATE: 06/27/20	DESCRIPTION: REVISIONS
REV: 44	DATE: 06/27/20	DESCRIPTION: REVISIONS
REV: 45	DATE: 06/27/20	DESCRIPTION: REVISIONS
REV: 46	DATE: 06/27/20	DESCRIPTION: REVISIONS
REV: 47	DATE: 06/27/20	DESCRIPTION: REVISIONS
REV: 48	DATE: 06/27/20	DESCRIPTION: REVISIONS
REV: 49	DATE: 06/27/20	DESCRIPTION: REVISIONS
REV: 50	DATE: 06/27/20	DESCRIPTION: REVISIONS
REV: 51	DATE: 06/27/20	DESCRIPTION: REVISIONS
REV: 52	DATE: 06/27/20	DESCRIPTION: REVISIONS
REV: 53	DATE: 06/27/20	DESCRIPTION: REVISIONS
REV: 54	DATE: 06/27/20	DESCRIPTION: REVISIONS
REV: 55	DATE: 06/27/20	DESCRIPTION: REVISIONS
REV: 56	DATE: 06/27/20	DESCRIPTION: REVISIONS
REV: 57	DATE: 06/27/20	DESCRIPTION: REVISIONS
REV: 58	DATE: 06/27/20	DESCRIPTION: REVISIONS
REV: 59	DATE: 06/27/20	DESCRIPTION: REVISIONS
REV: 60	DATE: 06/27/20	DESCRIPTION: REVISIONS
REV: 61	DATE: 06/27/20	DESCRIPTION: REVISIONS
REV: 62	DATE: 06/27/20	DESCRIPTION: REVISIONS
REV: 63	DATE: 06/27/20	DESCRIPTION: REVISIONS
REV: 64	DATE: 06/27/20	DESCRIPTION: REVISIONS
REV: 65	DATE: 06/27/20	DESCRIPTION: REVISIONS
REV: 66	DATE: 06/27/20	DESCRIPTION: REVISIONS
REV: 67	DATE: 06/27/20	DESCRIPTION: REVISIONS
REV: 68	DATE: 06/27/20	DESCRIPTION: REVISIONS
REV: 69	DATE: 06/27/20	DESCRIPTION: REVISIONS
REV: 70	DATE: 06/27/20	DESCRIPTION: REVISIONS
REV: 71	DATE: 06/27/20	DESCRIPTION: REVISIONS
REV: 72	DATE: 06/27/20	DESCRIPTION: REVISIONS
REV: 73	DATE: 06/27/20	DESCRIPTION: REVISIONS
REV: 74	DATE: 06/27/20	DESCRIPTION: REVISIONS
REV: 75	DATE: 06/27/20	DESCRIPTION: REVISIONS
REV: 76	DATE: 06/27/20	DESCRIPTION: REVISIONS
REV: 77	DATE: 06/27/20	DESCRIPTION: REVISIONS
REV: 78	DATE: 06/27/20	DESCRIPTION: REVISIONS
REV: 79	DATE: 06/27/20	DESCRIPTION: REVISIONS
REV: 80	DATE: 06/27/20	DESCRIPTION: REVISIONS
REV: 81	DATE: 06/27/20	DESCRIPTION: REVISIONS
REV: 82	DATE: 06/27/20	DESCRIPTION: REVISIONS
REV: 83	DATE: 06/27/20	DESCRIPTION: REVISIONS
REV: 84	DATE: 06/27/20	DESCRIPTION: REVISIONS
REV: 85	DATE: 06/27/20	DESCRIPTION: REVISIONS
REV: 86	DATE: 06/27/20	DESCRIPTION: REVISIONS
REV: 87	DATE: 06/27/20	DESCRIPTION: REVISIONS
REV: 88	DATE: 06/27/20	DESCRIPTION: REVISIONS
REV: 89	DATE: 06/27/20	DESCRIPTION: REVISIONS
REV: 90	DATE: 06/27/20	DESCRIPTION: REVISIONS
REV: 91	DATE: 06/27/20	DESCRIPTION: REVISIONS
REV: 92	DATE: 06/27/20	DESCRIPTION: REVISIONS
REV: 93	DATE: 06/27/20	DESCRIPTION: REVISIONS
REV: 94	DATE: 06/27/20	DESCRIPTION: REVISIONS
REV: 95	DATE: 06/27/20	DESCRIPTION: REVISIONS
REV: 96	DATE: 06/27/20	DESCRIPTION: REVISIONS
REV: 97	DATE: 06/27/20	DESCRIPTION: REVISIONS
REV: 98	DATE: 06/27/20	DESCRIPTION: REVISIONS
REV: 99	DATE: 06/27/20	DESCRIPTION: REVISIONS
REV: 100	DATE: 06/27/20	DESCRIPTION: REVISIONS
REV: 101	DATE: 06/27/20	DESCRIPTION: REVISIONS
REV: 102	DATE: 06/27/20	DESCRIPTION: REVISIONS
REV: 103	DATE: 06/27/20	DESCRIPTION: REVISIONS
REV: 104	DATE: 06/27/20	DESCRIPTION: REVISIONS
REV: 105	DATE: 06/27/20	DESCRIPTION: REVISIONS
REV: 106	DATE: 06/27/20	DESCRIPTION: REVISIONS
REV: 107	DATE: 06/27/20	DESCRIPTION: REVISIONS
REV: 108	DATE: 06/27/20	DESCRIPTION: REVISIONS
REV: 109	DATE: 06/27/20	DESCRIPTION: REVISIONS
REV: 110	DATE: 06/27/20	DESCRIPTION: REVISIONS
REV: 111	DATE: 06/27/20	DESCRIPTION: REVISIONS
REV: 112	DATE: 06/27/20	DESCRIPTION: REVISIONS
REV: 113	DATE: 06/27/20	DESCRIPTION: REVISIONS
REV: 114	DATE: 06/27/20	DESCRIPTION: REVISIONS
REV: 115	DATE: 06/27/20	DESCRIPTION: REVISIONS
REV: 116	DATE: 06/27/20	DESCRIPTION: REVISIONS
REV: 117	DATE: 06/27/20	DESCRIPTION: REVISIONS
REV: 118	DATE: 06/27/20	DESCRIPTION: REVISIONS
REV: 119	DATE: 06/27/20	DESCRIPTION: REVISIONS
REV: 120	DATE: 06/27/20	DESCRIPTION: REVISIONS
REV: 121	DATE: 06/27/20	DESCRIPTION: REVISIONS
REV: 122	DATE: 06/27/20	DESCRIPTION: REVISIONS
REV: 123	DATE: 06/27/20	DESCRIPTION: REVISIONS
REV: 124	DATE: 06/27/20	DESCRIPTION: REVISIONS
REV: 125	DATE: 06/27/20	DESCRIPTION: REVISIONS
REV: 126	DATE: 06/27/20	DESCRIPTION: REVISIONS
REV: 127	DATE: 06/27/20	DESCRIPTION: REVISIONS
REV: 128	DATE: 06/27/20	DESCRIPTION: REVISIONS
REV: 129	DATE: 06/27/20	DESCRIPTION: REVISIONS
REV: 130	DATE: 06/27/20	DESCRIPTION: REVISIONS
REV: 131	DATE: 06/27/20	DESCRIPTION: REVISIONS
REV: 132	DATE: 06/27/20	DESCRIPTION: REVISIONS
REV: 133	DATE: 06/27/20	DESCRIPTION: REVISIONS
REV: 134	DATE: 06/27/20	DESCRIPTION: REVISIONS
REV: 135	DATE: 06/27/20	DESCRIPTION: REVISIONS
REV: 136	DATE: 06/27/20	DESCRIPTION: REVISIONS
REV: 137	DATE: 06/27/20	DESCRIPTION: REVISIONS
REV: 138	DATE: 06/27/20	DESCRIPTION: REVISIONS
REV: 139	DATE: 06/27/20	DESCRIPTION: REVISIONS
REV: 140	DATE: 06/27/20	DESCRIPTION: REVISIONS
REV: 141	DATE: 06/27/20	DESCRIPTION: REVISIONS
REV: 142	DATE: 06/27/20	DESCRIPTION: REVISIONS
REV: 143	DATE: 06/27/20	DESCRIPTION: REVISIONS
REV: 144	DATE: 06/27/20	DESCRIPTION: REVISIONS
REV: 145	DATE: 06/27/20	DESCRIPTION: REVISIONS
REV: 146	DATE: 06/27/20	DESCRIPTION: REVISIONS
REV: 147	DATE: 06/27/20	DESCRIPTION: REVISIONS
REV: 148	DATE: 06/27/20	DESCRIPTION: REVISIONS
REV: 149	DATE: 06/27/20	DESCRIPTION: REVISIONS
REV: 150	DATE: 06/27/20	DESCRIPTION: REVISIONS
REV: 151	DATE: 06/27/20	DESCRIPTION: REVISIONS
REV: 152	DATE: 06/27/20	DESCRIPTION: REVISIONS
REV: 153	DATE: 06/27/20	DESCRIPTION: REVISIONS
REV: 154	DATE: 06/27/20	DESCRIPTION: REVISIONS
REV: 155	DATE: 06/27/20	DESCRIPTION: REVISIONS
REV: 156	DATE: 06/27/20	DESCRIPTION: REVISIONS
REV: 157	DATE: 06/27/20	DESCRIPTION: REVISIONS
REV: 158	DATE: 06/27/20	DESCRIPTION: REVISIONS
REV: 159	DATE: 06/27/20	DESCRIPTION: REVISIONS
REV: 160	DATE: 06/27/20	DESCRIPTION: REVISIONS
REV: 161	DATE: 06/27/20	DESCRIPTION: REVISIONS
REV: 162	DATE: 06/27/20	DESCRIPTION: REVISIONS
REV: 163	DATE: 06/27/20	DESCRIPTION: REVISIONS
REV: 164	DATE: 06/27/20	DESCRIPTION: REVISIONS
REV: 165	DATE: 06/27/20	DESCRIPTION: REVISIONS
REV: 166	DATE: 06/27/20	DESCRIPTION: REVISIONS
REV: 167	DATE: 06/27/20	DESCRIPTION: REVISIONS
REV: 168	DATE: 06/27/20	DESCRIPTION: REVISIONS
REV: 169	DATE: 06/27/20	DESCRIPTION: REVISIONS
REV: 170	DATE: 06/27/20	DESCRIPTION: REVISIONS
REV: 171	DATE: 06/27/20	DESCRIPTION: REVISIONS
REV: 172	DATE: 06/27/20	DESCRIPTION: REVISIONS
REV: 173	DATE: 06/27/20	DESCRIPTION: REVISIONS
REV: 174	DATE: 06/27/20	DESCRIPTION: REVISIONS
REV: 175	DATE: 06/27/20	DESCRIPTION: REVISIONS
REV: 176	DATE: 06/27/20	DESCRIPTION: REVISIONS
REV: 177	DATE: 06/27/20	DESCRIPTION: REVISIONS
REV: 178	DATE: 06/27/20	DESCRIPTION: REVISIONS
REV: 179	DATE: 06/27/20	DESCRIPTION: REVISIONS
REV: 180	DATE: 06/27/20	DESCRIPTION: REVISIONS
REV: 181	DATE: 06/27/20	DESCRIPTION: REVISIONS
REV: 182	DATE: 06/27/20	DESCRIPTION: REVISIONS
REV: 183	DATE: 06/27/20	DESCRIPTION: REVISIONS
REV: 184	DATE: 06/27/20	DESCRIPTION: REVISIONS
REV: 185	DATE: 06/27/20	DESCRIPTION: REVISIONS
REV: 186	DATE: 06/27/20	DESCRIPTION: REVISIONS
REV: 187	DATE: 06/27/20	DESCRIPTION: REVISIONS
REV: 188	DATE: 06/27/20	DESCRIPTION: REVISIONS
REV: 189	DATE: 06/27/20	DESCRIPTION: REVISIONS
REV: 190	DATE: 06/27/20	DESCRIPTION: REVISIONS
REV: 191	DATE: 06/27/20	DESCRIPTION: REVISIONS
REV: 192	DATE: 06/27/20	DESCRIPTION: REVISIONS
REV: 193	DATE: 06/27/20	DESCRIPTION: REVISIONS
REV: 194	DATE: 06/27/20	DESCRIPTION: REVISIONS
REV: 195	DATE: 06/27/20	DESCRIPTION: REVISIONS
REV: 196	DATE: 06/27/20	DESCRIPTION: REVISIONS
REV: 197	DATE: 06/27/20	DESCRIPTION: REVISIONS
REV: 198	DATE: 06/27/20	DESCRIPTION: REVISIONS
REV: 199	DATE: 06/27/20	DESCRIPTION: REVISIONS
REV: 200	DATE: 06/27/20	DESCRIPTION: REVISIONS

BLOCK 103
LOT 10
BOROUGH OF BELMAR
MONMOUTH COUNTY, NEW JERSEY

EXISTING CONDITION/DEMOLITION PLAN
SITE PLAN - UTILITY PLAN
SITE PLAN
419 TENTH AVENUE

CAD Drawing
829

Sheet
2 of 3

COPYRIGHT © 2020 J.K.R. ENGINEERING - ALL RIGHTS RESERVED - THE DESIGN ORIGINATOR AND THE DESIGNER OF THIS PROJECT. ANY REPRODUCTION OR TRANSMISSION OF THIS PROJECT WITHOUT THE WRITTEN PERMISSION OF J.K.R. ENGINEERING IS PROHIBITED.